



Romex  
INTERNATIONAL SCHOOL



# HOLIDAY

## Homework

Learn • Explore • Enjoy

Make your holidays  
meaningful and fun  
with learning,  
creativity and kindness.



WISHING YOU A HAPPY  
AND SAFE HOLIDAY!



### General Instructions:

- ❖ *Kindly follow the below mentioned instructions to do the Homework:  
The Holidays Homework has been divided into separate Categories. For example:*
  - Part – A (Written and Learning work)**
  - Part – B (Project work)**
  - Part – C (Assignments)***Do the Holidays Homework neatly & in legible handwriting.*
- ❖ *Apart from the Holidays Homework also help your ward to revise the syllabus done in the Class for all the subjects till date.*
- ❖ *Kindly prepare a beautiful folder for the holiday homework, decorate and label it well (refer to the sample pic).*
- ❖ ***Best 3 Holidays Homework per section shall be awarded and the best models shall be selected for Exhibition.***
- ❖ *Parents are requested to help their wards to complete the homework under their guidance.*
- ❖ *Holiday's homework should be submitted positively by **6<sup>th</sup> July 2026***

***The School also desires you to adhere to the following guidelines for a fulfilling break:***

1. *Wake up early in the morning.*
2. *Follow a Fitness Routine. Do easy exercises / go for running/walk with your parents early in the morning.*
3. *Indulge yourself in Sports and Games.*
4. *Study well.*
5. *Maintain Good Health and Hygiene.*
6. *Stay indoors and in shaded places as much as possible.*
7. *Use an umbrella / hat / cap when outside.*
8. *Drink enough water and salted drinks (lemonade, fruit juices, ORS) frequently. Avoid junk food & eat healthy homemade food.*
9. *Respect & obey your elders.*

### **Suggestion For Parents**

- \* *Make sure that you spend quality time with your ward.*
- \* *Giving them small responsibility in household chores will make them independent.*
- \* *Teach them the importance of moral values in life. Remember the four magic words ....PLEASE, THANK YOU, SORRY and EXCUSE ME. Help them to make these a part of their personality.*
- \* *Indulge yourself in various games with them.*
- \* *Read out any one Hindi/ English short story every day.*
- \* *Encourage them to converse in English at home.*



Enjoy, Fun &  
**Enriching**  
activities all  
through the break!



# EMBELLISHING SKILLS



**BOOK**

**READING**



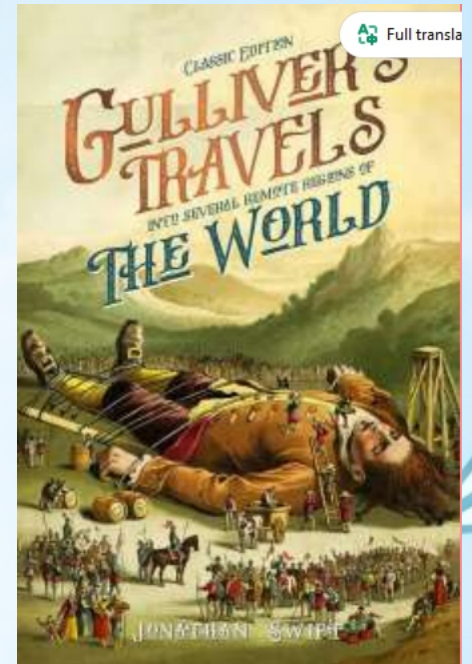
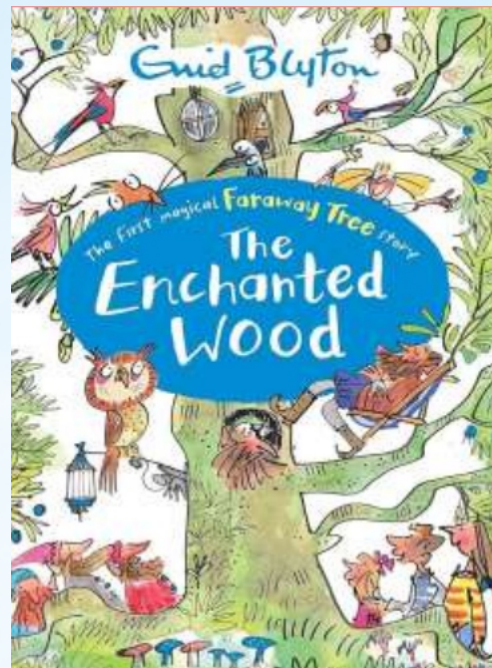

*Click The links below to read:*

**SUDHA MURTY**  
**The Magic of the Lost Temple**

<https://www.youtube.com/watch?v=QT1WOpIfHIQ>

**GULLIVER'S TRAVELS**

<https://www.youtube.com/watch?v=fiCMKLg3SxM>



**During this summer break, you are encouraged to make good use of your time by learning the school prayer and the school song.**

**You will find lyrics of the school prayer and song in your school diary.**

**The songs have been shared with you in the link. Please take time to learn and practice both regularly so that you are confident and ready when school reopens.**

<https://www.youtube.com/watch?v=CKMW4h1n6js>

# Mirror Talks- Speak & Reflect



Each day, the child will stand in front of a mirror and speak for one minute on a topic of his/her choice while observing himself/herself, smiling, and speaking clearly. After the talk, he/she will write a simple sentence in his/her mirror journal summarizing what he/she said. Click on the link below for the details of the activity.

# Manner-A-Table



Watch the given video and  
practice the table manners at home.

Record your video of practicing the same.

# Folding Clothes



## Try It Out! What to do:

1. Choose 4-5 items, including tricky ones like a shirt or jeans.
2. Learn folding techniques by observing an adult or using a video tutorial.
3. Practice folding weekly and try helping others too.
4. Create a collage or step-by-step guide of your folding process. Paste or bring it after the holidays.
5. Write a short paragraph on what you learned and how it made you feel. Ex. : "This task taught me discipline and helped me support my family in small ways."

# **SORT & KNOT**



- Learn How to tie your shoe lace.
- Arrange your book shelf and bag  
(According to the class time table)

# Arrange Your Wardrobe



Learn to arrange your wardrobes. Children learn to organize their wardrobes by sorting cloths by type, season, or colour while creating a neat, accessible space.



# Summer Assignment

Subject : Science

Name \_\_\_\_\_ Roll No: \_\_\_\_\_ Class & Sec \_\_\_\_\_

---

## Part A

- ✓ Revise all the work done in class.
- ✓ Learn all the note book and book work.

## Part –B

### CHARTS

1. Make a chart of the structure of plant cell (Roll no. 1 to 10)
2. Make a chart of the structure of animal cell (Roll no. 11 to 20)
3. Make a chart of nerve cell. (Roll 21 to 30)
4. Make a chart of muscle cell. (Roll 31 to 40)

## Summer Assignment

Subject : Science

Name \_\_\_\_\_ Roll No: \_\_\_\_\_ Class & Sec \_\_\_\_\_

---

### ASSIGNMENT – 1

**1. Cell wall is not found in:**

(a) Plant cell (b) Animal cell (c) Bacterial cell (d) Fungal cell

**2. Secondary wall is present on the inner side of:**

(a) Primary wall (b) Middle lamella (c) Cell membrane (d) Cytoplasm

**3. Cell membrane is found**

(a) Only in plant cell (b) Only in animal cell (c) Only in bacterial cell (d) In all types of cell

**4. Mitochondria take part in :**

(a) Energy production (b) Protein synthesis (c) Cellulose (d) None of these

**5. Cell is latin word for 'a little room'. Who coined the term cell?**

(a) Robert book (b) Robert hooke (c) Charles hooke (d) leeuwenhoek

**6. Chloroplast is a pigment which gives .....**

(A) Green colour (b) No colour (c) Colour other than green (d) All of the above

**7. Ribosomes take part in**

(a) Secretion of enzymes (b) protein enzymes (c) Production of energy (d) Carbohydrate Formation

**8. The process of movement of molecules from lower to higher concentration is called**

(a) Diffusion (b) Osmosis (c) Active transport (d) passive transport

Question 9 to 13 are Assertion and Reason. Select anyone of the given options below for these.

- a) If both A and R are true and R is correct explanation of A
- b) Both A and R are true and R is not correct explanation of A
- c) A is true and R is false.
- d) A is false and R is true.
- e) Both A and R are false

**9. Assertion: Cell is structural and functional unit of life.**

**Reason : Some of the cells can perform all the functions of a living organism.**

Ans. \_\_\_\_\_

**10.Assertion :Animal cells show large variation in their shape.**

**Reason: Cell membrane is the outer cover of animal cell and it provides flexibility. 11.Assertion: Endoplasmic reticulum forms the transport system of the cell .**

Reason : : Endoplasmic reticulum is the network of membranes which provides channel for transport .

Ans. \_\_\_\_\_

**12.Assertion :The plant cell has fixed shape and rigidity.**

**Reason :The cell membrane gives fixed shape and rigidity to the cell.**

Ans. \_\_\_\_\_

**13.Assertion :Cell wall is non living structure.**

Reason: Cell wall does not give shape to the cell.

Ans. \_\_\_\_\_

**14.Case based Question:-**

Siddharth's mother was cutting an onion. Suddenly he observed a thin transparent layer in onion.

He was very surprised to see it. Siddharth's mother is a science teacher,so she explained that this is the onion

peel. Then, she prepared a slide of onion peel and explained the structure of its cells.

A) Name the stain used in preparing slide of plant cells .

---

---

B ) What is the shape of cells of onion peel?

---

---

## ASSIGNMENT -2

### A. Fill in the Blanks

1.The heating effect of electric current is used in an electric \_\_\_\_\_.

2.A thin wire that melts easily in an electric circuit is called a \_\_\_\_\_.

3. The magnetic effect of electric current was discovered by \_\_\_\_\_.
4. A device used to protect electrical appliances from short circuits is called an electric \_\_\_\_\_.
5. The coil of wire wound around an iron core is called an \_\_\_\_\_.
6. A compass needle gets deflected due to the \_\_\_\_\_ effect of electric current.
7. The SI unit of electric current is \_\_\_\_\_.
8. Electric bulbs produce light due to the \_\_\_\_\_ effect of current.
9. The wire used in a fuse has a \_\_\_\_\_ melting point.
10. When a current passes through a conductor, it may produce heat and \_\_\_\_\_ effects.

### **B. One Word Answer Questions.**

1. Name the device that converts electrical energy into heat for cooking. \_\_\_\_\_
2. Name the scientist who discovered the magnetic effect of electric current. \_\_\_\_\_
3. What is the unit of electric current? \_\_\_\_\_
4. Name the safety device used in electric circuits. \_\_\_\_\_
5. What do we call a temporary magnet made using electric current? \_\_\_\_\_

### **C. Assertion–Reason Questions.**

Directions: Read the Assertion (A) and Reason (R). Choose the correct option.

- (a) Both A and R are true and R is the correct explanation of A.
- (b) Both A and R are true but R is not the correct explanation of A.
- (c) A is true but R is false.
- (d) A is false but R is true.

**1. Assertion (A): A fuse wire melts during excessive current flow.**

**Reason (R): Fuse wire has a low melting point.**

Ans.

**2. Assertion (A): A compass needle deflects near a current-carrying wire.**

**Reason (R): Electric current produces a magnetic effect.**

Ans.

**3. Assertion (A): An electromagnet can be switched on and off.**

**Reason (R): An electromagnet works without electric current.**

Ans.

**4.Assertion (A): Electric irons become hot when connected to a power source.**

**Reason (R): Electric current produces a heating effect.**

Ans.

**D. Case-Based Questions (2)**

**Case Study – 1**

Rohan noticed that during a short circuit, the fuse in his house melted and the supply stopped. His father explained that the fuse protects electrical appliances from damage.

**Questions:**

a) Why did the fuse wire melt?

---

---

b) Which property of fuse wire makes it suitable for safety purposes?

---

---

c) What is meant by a short circuit?

---

---

**Case Study – 2**

In a science lab, students wrapped insulated copper wire around an iron nail and connected it to a battery. The nail started attracting paper clips.

**Questions:**

a) What is the setup called?

---

---

b) Why did the iron nail attract paper clips?

---

---

c) Name one practical use of this device in daily life.

## Summer Assignment

Subject : Sanskrit

Name \_\_\_\_\_ Roll No: \_\_\_\_\_ Class & Sec \_\_\_\_\_

### ( खंड अ ) पठितबोध

- 1- विद्यार्थी अपनी पाठ्यपुस्तक में गतिविधि 1,2,5,7,9,10 पूर्ण करें ।
- 2- अकारांत पुलिग बालक शब्द तथा ईकारांत स्त्रीलिग नदी शब्द को कंठस्थ कर पुस्तिका में लिखें।
- 3- पश्य (देखना) धातु के पांचो लकार कंठस्थ कर पुस्तिका में लिखें।

### (खंड ब) परियोजना कार्य

- 4- अनुक्रमांक - (1 से 8) विद्यार्थी पंच लक्षणम् शीर्षक चार्ट पेपर पर बनाएं।
- 5- अनुक्रमांक - (9 से 16) दैनिक वस्तुओं के नाम चित्र सहित चार्ट पेपर पर बनाएं बनाएं।
- 6- अनुक्रमांक (16से24)संस्कृत में तिथियोंके नाम A3 पेपर पर लिखें ।
- 7- अनुक्रमांक (25से32) विद्यार्थी अपनी पुस्तक की वंदना को A3 पेपर पर सुंदर-सुंदर चित्र सहित लिखें ।

## Summer Assignment

Subject : Science

Name \_\_\_\_\_ Roll No: \_\_\_\_\_ Class & Sec \_\_\_\_\_

1- निम्नलिखित सूक्तियों का हिंदी में अनुवाद कीजिए।

- क. अहिंसा परमो धर्मः ।
- ख. आलस्योपहता विद्या।
- ग. अविद्या जीवनम् शून्यम्।
- घ. अनभ्यासहता विद्या।
- ङ. विद्या ददाति विनयम्।
- च. विद्वान् सर्वत्र पूज्यते ।
- छ. विद्याधनम् सर्वधन-प्रधानम्।
- ज. आचार्य देवो भव

2-निम्नलिखित प्रश्नों में से सही विकल्प छांटकर लिखिए ।

1. संस्कृत में कितने पुरुष होते हैं?

- i. तीन
- ii. चार
- iii. दो
- iv. पाँच

2. संस्कृत में वर्तमान काल को क्या कहते हैं?

- i. लट् लकार
- ii. लुट् लकार
- iii. लोट् लकार
- iv. लङ् लकार

3. संस्कृत में कर्ता शब्द कौन से होते हैं?

i. सः, तौ, ते

ii. प्रथम, द्वितीय, तृतीय

iii. पाँच लकार

iv. तीन पुरुष

4. नम् धातु लट् लकार मध्यम पुरुष द्विवचन का रूप लिखिए।

i. नमथः

ii. नमसि

iii. नमामि

iv. नमथ

5. विद्यार्थियों के कितने लक्षण होते हैं?

i. चार

ii. पाँच

iii. तीन

iv. दो

6. विद्या अर्जन के लिए विद्यार्थी को किन-किन का त्याग करना चाहिए?

i. आलस्य

ii. निद्रा

iii. समय का सदुपयोग

iv. उपर्युक्त सभी

7. कौए को संस्कृत में क्या कहते हैं?

i. काकः

ii. कपोतः

iii. वकः

iv. इनमें से कोई नहीं

8. कृ धातु लोट् लकार उत्तम पुरुष द्विवचन का रूप बताइए।

i. करवाव

ii. करवावहै

iii. करवाव

iv. करवावः

9. पाँच लकारों के नाम लिखिए।

उत्तर:

10. शब्द रूपों में कितनी विभक्तियाँ होती हैं?

उत्तर:

## Summer Assignment

Subject : English

Name \_\_\_\_\_ Roll No: \_\_\_\_\_ Class & Sec \_\_\_\_\_

### Dear Students,

- Make your holidays enjoyable and productive with these simple and interesting activities. Complete all work neatly in your English notebook.
- Complete all the work neatly.

### Part A Reading Comprehension

Read the passage carefully and answer the questions.

#### Passage:

Riya loved visiting her grandmother during summer vacations. Her grandmother lived in a small village surrounded by green fields and trees. Every morning, Riya helped her water the plants and feed the birds. In the evening, they sat together and listened to stories about honesty, kindness, and hard work. Riya enjoyed the peaceful village life and learned many good habits from her grandmother.

#### Questions:

- Q1- Where did Riya visit during summer vacations?  
Q2- What did Riya do every morning?  
Q3- What stories did grandmother tell?  
Q4- Find one word from the passage that means "calm".  
Q5- Write the opposite of "kindness".

### Part B

#### Grammar Practice

##### A. Fill in the blanks with suitable conjunctions (and, but, because, or)

- 1- I wanted to play cricket \_\_\_\_\_ it was raining.  
2- Would you like tea \_\_\_\_\_ coffee?  
3- She is smart \_\_\_\_\_ hardworking.  
4- He was tired \_\_\_\_\_ he slept early.  
5- The room was clean \_\_\_\_\_ small.

##### B. Fill in the blanks with is, am, are

- 1- They \_\_\_\_\_ going to school.  
2- I \_\_\_\_\_ very excited today.  
3- She \_\_\_\_\_ my best friend.  
4- We \_\_\_\_\_ learning English grammar.  
5- The boys \_\_\_\_\_ playing football.

##### C. Choose the correct verb

- 1- She \_\_\_\_\_ (write/writes) neatly.  
2- They \_\_\_\_\_ (play/plays) in the park every evening.  
3- He \_\_\_\_\_ (eat/eats) breakfast at 8 a.m.  
4- We \_\_\_\_\_ (watch/watches) television at night.  
5- The bird \_\_\_\_\_ (fly/flies) in the sky.

### Q3. Pronouns

Replace the underlined words with correct pronouns and rewrite the sentences.

- 1- Rahul and Aman are good friends.
- 2- My mother cooks delicious food.
- 3- The dog is barking loudly.
- 4- Riya and I are going to the market.
- 5- The books are on the table.

### Q4. Punctuation

Rewrite the sentences using correct punctuation and capital letters.

- 1- where do you live
- 2- my favourite subject is english
- 3- we visited delhi last month
- 4- do you like ice cream
- 5- my brother plays football

### Q5. Vocabulary

- Write opposites of the following words:
  - 1-Happy - \_\_\_\_\_
  - 2-Big - \_\_\_\_\_
  - 3-Early - \_\_\_\_\_
  - 4-Hot - \_\_\_\_\_
  - 5-Beautiful - \_\_\_\_\_

### Q6. Creative Writing

- Write a paragraph (100–120 words) on any one topic:
  - 1-My Favourite Festival
  - 2-A Visit to a Park
  - 3-Importance of Trees
  - 4-My Best Friend

## Summer Assignment

Subject : English

Name \_\_\_\_\_ Roll No: \_\_\_\_\_ Class & Sec \_\_\_\_\_

---

### Part C

#### Q7. Activity Work

- Do any one activity:
- Make a colourful chart on "Parts of Speech"

• OR

- Paste 5 pictures from newspapers/magazines and write 2 lines about each picture.

#### Q8. Reading Task

Read any English story book of Sudha Murty during holidays and write:

- Name of the book
- Main characters

What you learnt from the story

#### Q9. Make a vlog on any one topic: (Note: The video should not be more than 5 minutes.)

Option 1: My Visit to Nani House

Option 2: The Place I Visit in Summer Vacation

- Complete the work neatly.
- Use blue/black pen only.
- Submit homework after the summer vacation.

## Summer Assignment

Subject : Hindi

Name \_\_\_\_\_ Roll No: \_\_\_\_\_ Class & Sec \_\_\_\_\_

### भाग – A : पठन एवं रचनात्मक गतिविधियाँ

1. समाचार खोजो गतिविधि 📰 समाचार-पत्र से:

2 राष्ट्रीय समाचार 1 खेल समाचार 1 पर्यावरण से जुड़ा समाचार

काटकर चिपकाइए तथा प्रत्येक पर 2 पंक्तियाँ लिखिए।

2. मेरा पसंदीदा लेखक 🖋️

किसी एक हिन्दी लेखक/कवि के बारे में लिखिए: नाम, प्रसिद्ध रचना, 5 पंक्तियों में परिचय चित्र भी बना सकते हैं।

3. कहानी निर्माण गतिविधि 📖

निम्न शब्दों का प्रयोग करते हुए एक छोटी कहानी लिखिए: विद्यालय, मित्र, वर्षा, पेड़, साहस (100-120 शब्द)

### भाग – B : व्याकरण एवं भाषा कौशल

4. पर्यायवाची पुष्प 🌸 एक फूल बनाइए और बीच में लिखिए: “ खुशी ” पंखुड़ियों में उसके पर्यायवाची शब्द लिखिए:

प्रसन्नता

आनंद

उल्लास

हर्ष

खुशी

5. मुहावरा कार्ड गतिविधि 5 छोटे कार्ड बनाइए और उन पर लिखिए:

1 मुहावरा - उसका अर्थ , वाक्य प्रयोग

6. शब्द भंडार चुनौती 🧠 प्रतिदिन एक नया हिन्दी शब्द लिखिए:

शब्द - अर्थ, वाक्य कम से कम 15 शब्द लिखें।

## Summer Assignment

Subject : Hindi

Name \_\_\_\_\_ Roll No: \_\_\_\_\_ Class & Sec \_\_\_\_\_

### भाग – C : रचनात्मक लेखन

7. डायरी लेखन 📅 विषय: “मेरी सबसे यादगार छुट्टी” (80–100 शब्द)
8. पोस्टर निर्माण 🎨 विषय: “जल संरक्षण” पोस्टर में शामिल करें: नारा, चित्र, 3 सुझाव लिखिए
9. संवाद लेखन दो मित्रों के बीच संवाद लिखिए: “मोबाइल का सही उपयोग”(8–10 पंक्तियाँ)
10. परिवार साक्षात्कार 🗣️ घर के किसी बड़े सदस्य से पूछिए: उनके बचपन का खेल उनका विद्यालय, उनकी एक अच्छी आदत- उत्तर 6–8 पंक्तियों में लिखिए।
11. हिन्दी शब्द खोज 🔍 अपने आसपास दिखाई देने वाले हिन्दी शब्द लिखिए: दुकान, अखबार, पुस्तक, पोस्टर आदि कम से कम 15 शब्द लिखिए।

“एक दिन बिना मोबाइल”, एक दिन कुछ समय बिना मोबाइल बिताइए।  
फिर लिखिए: आपने क्या किया? कैसा महसूस हुआ? आपने क्या सीखा? (5–6 पंक्तियाँ)

### ■ अतिरिक्त कार्यपत्रक

### हिन्दी व्याकरण कार्यपत्रक – कक्षा 8

#### A. बहुविकल्पीय प्रश्न (MCQs)

1. ‘सुंदर’ शब्द का विलोम है:  
(क) अच्छा (ख) कुरूप (ग) महान (घ) छोटा
2. ‘विद्यालय’ कौन-सा संज्ञा शब्द है?  
(क) व्यक्तिवाचक (ख) जातिवाचक (ग) भाववाचक (घ) समूहवाचक
3. ‘मैं विद्यालय जाता हूँ।’ में सर्वनाम है:  
(क) विद्यालय (ख) जाता (ग) मैं (घ) हूँ
4. ‘तेज’ का पर्यायवाची है:

(क) मंद (ख) तीव्र (ग) हल्का (घ) धीमा

5. 'राम ने फल खाया।' में क्रिया शब्द है:

(क) राम (ख) फल (ग) ने (घ) खाया

## B. रिक्त स्थान भरिए

1. भारत की राजधानी \_\_\_\_\_ है।
2. 'ईमानदार' का विलोम \_\_\_\_\_ है।
3. संज्ञा के स्थान पर प्रयोग होने वाले शब्द को \_\_\_\_\_ कहते हैं।
4. 'कलम' शब्द \_\_\_\_\_ लिंग है।
5. 'बहुत सुंदर' में \_\_\_\_\_ विशेषण है।

## C. सत्य / असत्य

1. क्रिया कार्य के होने का बोध कराती है। \_\_\_\_\_
2. 'लड़का' स्त्रीलिंग शब्द है। \_\_\_\_\_
3. पर्यायवाची समान अर्थ वाले शब्द होते हैं। \_\_\_\_\_
4. पत्र लेखन एक लेखन कौशल है। \_\_\_\_\_
5. 'हम' एक सर्वनाम है। \_\_\_\_\_

## D. लेखन कौशल

1. अनुच्छेद लेखन विषय: "स्वच्छ भारत अभियान" (80-100 शब्द)
2. पत्र लेखन  
अपने मित्र को ग्रीष्मावकाश बिताने के लिए आमंत्रित करते हुए पत्र लिखिए।
3. विज्ञापन लेखन विषय: "पुरानी पुस्तकें बेचनी हैं" एक छोटा विज्ञापन तैयार कीजिए।



## Summer Assignment

Subject : Social Science

Name \_\_\_\_\_ Roll No: \_\_\_\_\_ Class & Sec \_\_\_\_\_

### General Instructions

Complete the work neatly in a notebook or on A4 sheets.  
Use simple and low-cost materials available at home.  
Use colours and creativity wherever needed.  
Do all activities independently.

### SECTION A (All students)

1. Revise and complete all the work done in class.
2. Learn all the work of notebook and book.
3. Learn and revise new words related to the completed chapters.
4. Complete and solve book activity in the book.

### SECTION – B

#### 1. Climate Observer Activity (All students)

Observe weather conditions for one week and prepare a chart.

Day	Weather	Humidity Feeling	One Environmental Observation

#### 2. Sustainable Living Challenge (Roll number 1-8)

Write any:

5 eco-friendly habits you already follow

5 habits you want to improve

Decorate with simple symbols/drawings.

---

### **3. Disaster Awareness Poster (Roll number 9-16 )**

Make a poster on any one:

Flood Safety  
Earthquake Safety  
Heatwave Safety

- Fire Safety

Include:

- 3 safety tips
  - Emergency helpline number
- 

### **4. Resource Mapping Activity (All students)**

Make a list of natural resources used in your home in one day.

Example:

- Water
- LPG
- Electricity
- Paper

### **5. Freedom Fighter Spotlight (Roll number 17 to 24)**

Prepare a short profile of any one freedom fighter:

- Mahatma Gandhi
- RaniLakshmibai
- Bhagat Singh
- Subhas Chandra Bose

Include:

- Birthplace
- Contributions
- Famous slogan/quote

Paste or draw a picture.

---

**6. Timeline of Indian History** ⌚ (Roll number 25 to 35)

Prepare a simple timeline including:

- Revolt of 1857
  - Formation of INC
  - Dandi March
  - Independence of India
- 
-



**Romex**  
INTERNATIONAL SCHOOL

## Summer Assignment

Subject : Social Science

Name \_\_\_\_\_ Roll No: \_\_\_\_\_ Class & Sec \_\_\_\_\_

### SECTION – C

#### Assignment (All students)

#### A. Multiple Choice Questions (MCQs)

1. Which movement was started by Mahatma Gandhi?
  - (a) Quit India Movement
  - (b) Green Revolution
  - (c) Chipko Movement
  - (d) White Revolution
2. Which is a renewable source of energy?
  - (a) Coal
  - (b) Petroleum
  - (c) Solar Energy
  - (d) Diesel
3. The Constitution of India came into force on:
  - (a) 15 August 1947
  - (b) 26 January 1950
  - (c) 2 October 1948
  - (d) 26 November 1949
4. Which layer of the Earth supports life?
  - (a) Lithosphere
  - (b) Atmosphere
  - (c) Biosphere
  - (d) Core
5. The Revolt of 1857 first started from:
  - (a) Delhi
  - (b) Meerut
  - (c) Kanpur
  - (d) Lucknow

#### B. Fill in the Blanks

1. The Father of the Nation is \_\_\_\_\_.
2. \_\_\_\_\_ is the capital of India.
3. Forests help in maintaining ecological \_\_\_\_\_.
4. The national anthem of India was written by \_\_\_\_\_.
5. The Parliament consists of Lok Sabha and \_\_\_\_\_.

**C. True / False**

1. Solar energy is non-renewable. \_\_\_\_\_
2. Citizens have Fundamental Rights and Duties. \_\_\_\_\_
3. The Revolt of 1857 is also known as the First War of Independence. \_\_\_\_\_
4. Pollution helps the environment. \_\_\_\_\_
5. The President is the head of the Indian government. \_\_\_\_\_

**D. Match the Following**

Column A	Column B
1. Mahatma Gandhi	(a) Fundamental Rights
2. Constitution	(b) Non-violence
3. Solar Energy	(c) Renewable Resource
4. Parliament	(d) Law-making body

**E. Map Work**

On the outline map of India, mark and label:

1. New Delhi
2. Mumbai
3. Kolkata
4. Chennai
5. River Ganga
6. Arabian Sea
7. Bay of Bengal
8. Meerut

## Summer Assignment

Subject : Computer

Name \_\_\_\_\_ Roll No: \_\_\_\_\_ Class & Sec \_\_\_\_\_

---

### Part – A : Revision Work

#### Chapter 1 – Networking Concepts

- 1) Define Computer Network.
- 2) Write types of networks (LAN, MAN, WAN).
- 3) Difference between Internet and Intranet.
- 4) Explain Network Topology.
- 5) Write advantages of networking.
- 6) Define Server and Client.
- 7) What is Wi-Fi?
- 8) Explain communication devices used in networking.
- 9) Write uses of the Internet.
- 10) Draw and label any one network topology.

#### Chapter 2 – Introduction to Access 2016

- 1) Define Database.
- 2) What is MS Access 2016?
- 3) Write features of MS Access.
- 4) Explain Table, Record and Field.
- 5) Difference between Data and Information.
- 6) What is Primary Key?
- 7) Write steps to create a database in Access 2016.
- 8) Explain Forms and Queries.
- 9) Write uses of database management system.
- 10) Draw the MS Access 2016 window and label its parts.

## **Part – B : Charts & Models**

(Roll Number Wise Activity)

Roll No. 1 – 5

1) Chart on Types of Networks

Roll No 6 – 10

2) Model of LAN Network

Roll No . 11 – 15

3) Chart on Network Topologies

Roll No . 16 – 20

4) Chart on Internet Services

Roll No . 21 – 25

5) Model of Communication Devices

Roll No . 26 – 30

7) Chart on Advantages of Networking

Roll No . 31 – 35

8) Model of Database System

Roll No . 36 – 40

9) Chart on MS Access 2016 Features



## Summer Assignment

Subject : Computer

Name \_\_\_\_\_ Roll No: \_\_\_\_\_ Class & Sec \_\_\_\_\_

---

### Worksheet – Chapter 1 (Networking Concepts)

#### A. Fill in the Blanks

- 1) A group of connected computers is called a \_\_\_\_\_.
- 2) \_\_\_\_\_ stands for Local Area Network.
- 3) The Internet is the largest \_\_\_\_\_.
- 4) A device that connects networks is called a \_\_\_\_\_.
- 5) Wi-Fi is a \_\_\_\_\_ technology.

#### B. True / False

- 1) WAN covers a small area only. \_\_\_\_\_
- 2) Router is a networking device. \_\_\_\_\_
- 3) Internet and Intranet are same. \_\_\_\_\_
- 4) LAN is used in schools and offices. \_\_\_\_\_
- 5) Network helps in sharing resources. \_\_\_\_\_

#### C. Short Answer Questions

- 1) What is a network?
- 2) Define LAN and WAN.
- 3) What is topology?
- 4) Write any two advantages of networking.
- 5) What is the use of Internet?

### Worksheet – Chapter 2 (Introduction to Access 2016)

#### A. Fill in the Blanks

- 1)MS Access is a \_\_\_\_\_ software.
- 2)A collection of related data is called a \_\_\_\_\_.
- 3)A row in a table is called a \_\_\_\_\_.
- 4)\_\_\_\_\_ uniquely identifies each record.
- 5)Tables are used to store \_\_\_\_\_.

#### B. True / False

- 1)MS Access is used for database management. \_\_\_\_\_
- 2)A field contains complete information of one person. \_\_\_\_\_
- 3)Queries help to search data. \_\_\_\_\_
- 4)Database stores organized information. \_\_\_\_\_
- 5)Forms are used for data entry. \_\_\_\_\_

#### C. Short Answer Questions

- 1)What is database?
- 2)Define record and field.
- 3)What is a primary key?
- 4)Write any two features of MS Access 2016.
- 5)What is the use of forms in Access?

#### Instructions

- 1)Complete all work neatly in Computer Holiday Homework Notebook.
- 2)Use coloured pens and charts wherever required.
- 3)Submit homework after summer vacation.
- 4)Models and charts should be creative and attractive.
- 5)Maintain proper handwriting and presentation.

## Summer Assignment

Subject : Mathematics

Name \_\_\_\_\_ Roll No: \_\_\_\_\_ Class & Sec \_\_\_\_\_

---

### PART - A

1. Using appropriate properties, find:

(i)  $-2/3 \times 3/5 + 5/2 - 3/5 \times 1/6$

(ii)  $2/5 \times (-3/7) - 1/6 \times 3/2 + 1/14 \times 2/5$

2. Verify that:  $-(-x) = x$  for:

(i)  $x = 11/15$

(ii)  $x = -13/17$

3. Find the multiplicative inverse of the following:

(i) -13

(ii)  $-13/19$

(iii)  $1/5$

(iv)  $-5/8 \times (-3/7)$

(v)  $-1 \times (-2/5)$

(vi) -1

4. Write:

(i) The rational number that does not have a reciprocal.

(ii) The rational numbers that are equal to their reciprocals.

(iii) The rational number that is equal to its negative.

5. Fill in the blanks.

(i) Zero has \_\_\_\_\_ reciprocal.

(ii) The numbers \_\_\_\_\_ and \_\_\_\_\_ are their own reciprocals

(iii) The reciprocal of - 5 is \_\_\_\_\_.

(iv) Reciprocal of  $1/x$ , where  $x \neq 0$  is \_\_\_\_\_.





(v) The product of two rational numbers is always a \_\_\_\_\_.

6. Represent these numbers on the number line.

(i) 7/4

(ii) -5/6

7. Examine the table. (Each figure is divided into triangles and the sum of the angles deduced from that.)

Figure				
Side	3	4	5	6
Angle sum	$180^\circ$	$2 \times 180^\circ$ $= (4 - 2) \times 180^\circ$	$3 \times 180^\circ$ $= (5 - 2) \times 180^\circ$	$4 \times 180^\circ$ $= (6 - 2) \times 180^\circ$

What can you say about the angle sum of a convex polygon with number of sides? (a) 7 (b) 8 (c) 10 (d) n

**PART - B**

7. Find the angle measure of x in the following figures.

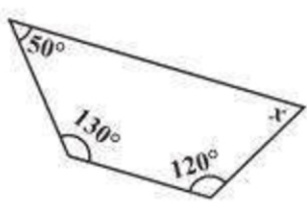

(a)

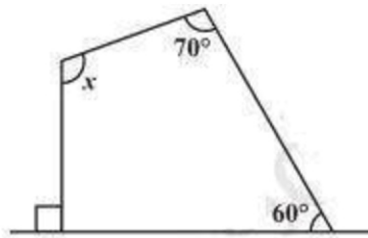

(b)

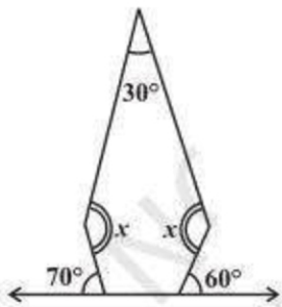

(c)

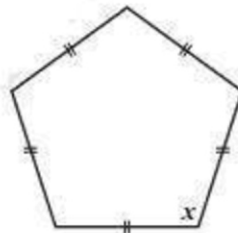

(d)

8. Find x in the following figures.

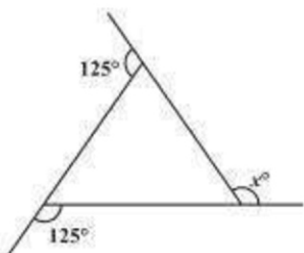

(a)

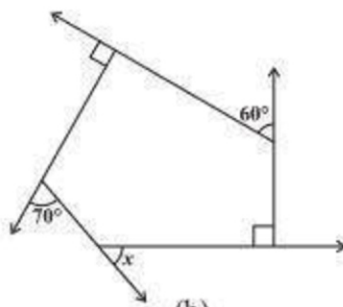

(b)

**PART - C**

**9. Find the measure of each exterior angle of a regular polygon of**

**(i) 9 sides (ii) 15 sides**

**10. SOLVE**

**(i)  $(-4)^4 \div (-4)^8$**

**(ii)  $(1/2^3)^2$**

**(iii)  $-(3)^4 \times (5/3)^4$**

**(iv)  $(3^{-7} \div 3^{-10}) \times 3^{-5}$**

**(v)  $2^{-3} \times (-7)^{-3}$**

**11. Write each of the following as percentage.**

**(i)  $7/25$**

**(ii)  $14/625$**

**(iii)  $5/8$**

**(iv) 0.8**

**(v) 0.005**

**12. Balanced diet should contain 12% of proteins, 25% of fats and 63% of carbohydrates. If a child needs 2600 calories in this food daily, find in calories the amount of each of these in his daily food intake.**

**13. A cricketer scored a total of 62 runs in 96 balls. He hit 3 sixes, 8 fours, 2 two's and 8 singles. What percentage of the total runs came in**

**(i) Sixes**

**(ii) 4's**

**(iii) 2's**

**(iv) Singles**